

Aluminum Base and Cap Installation System

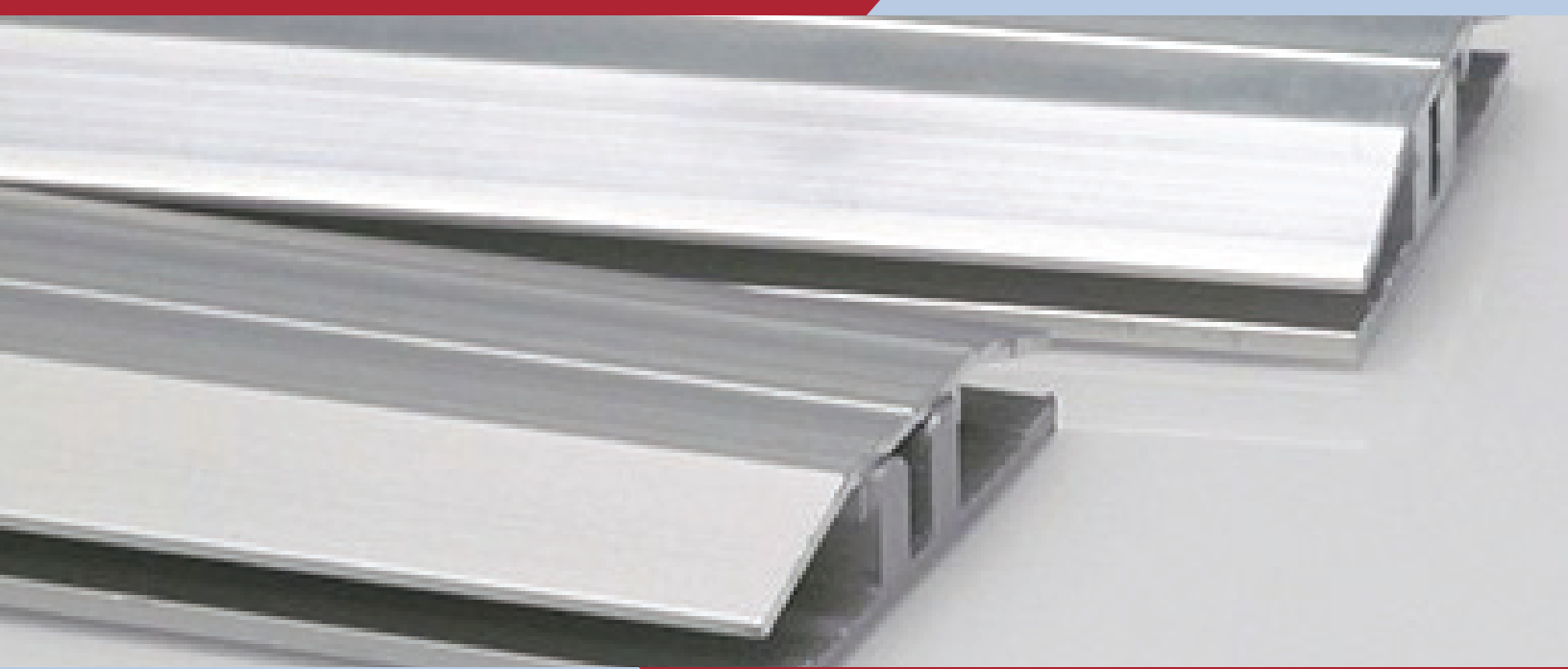

Focused on the Customer Experience



TABLE OF CONTENTS

Typical Installation Details 2

Ridge Details 3

Eave Details 6

Gambrel Double Slope Details 7

Roof Corners 8

Wall Corners 10

Butt to Siding 10

Clerestory Wall Details 11

Overlap Details 12

Splice Details 13

Roof Transition Details 13

Blocking Spacer w/no Drip Coatings 15

APPENDIX

Polycarbonate Specs 16

Vent Tape 17

Sealant Usage 17

Screws 17

General Information 19

TYPICAL INSTALLATION DETAILS

Base and Cap Layout Over Roof Purlins or Wall Girts

- Outside of building to center of first or last base 48-1/2". Intermediate bases 49" on-center.
- Above dimensions same for vertical rafters and studs.
- U-Profile: Lower edge of roof sheets, top and bottom of walls, bottom gable end walls, around doors and fans.
- Screws for attaching base to frame and cap to base are included when base and cap is ordered.
- Screws for corner, at top and bottom of polycarbonate sheet, and in body of sheet need to be purchased separately.

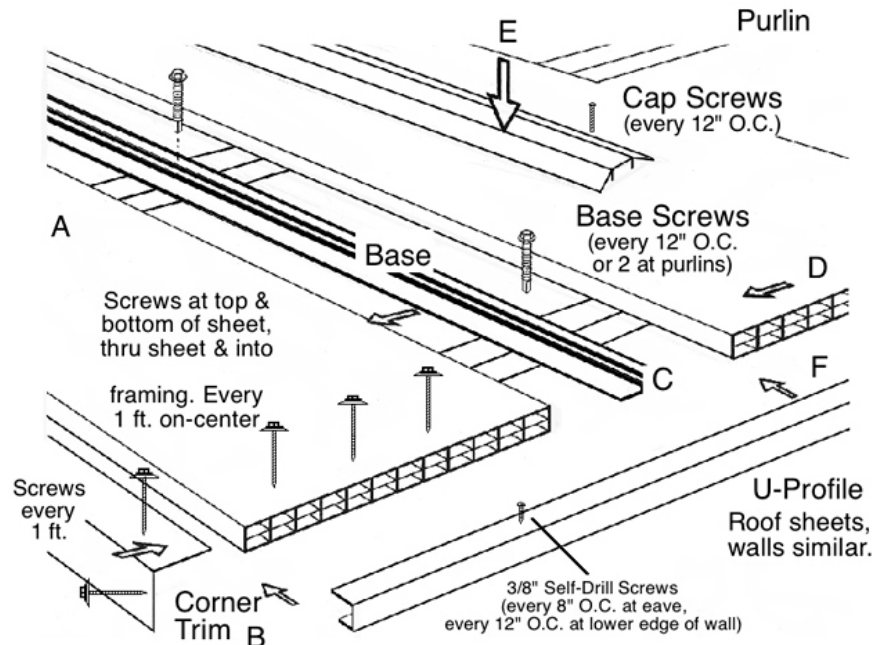

Note: Always pre-drill holes in Base and Cap for screw placement. Self-drilling screws are 'never' meant to drill through these components. Self-drill screws pass through components, fastening both to the frame.

Base and Cap Exploded View - Sheet Joining

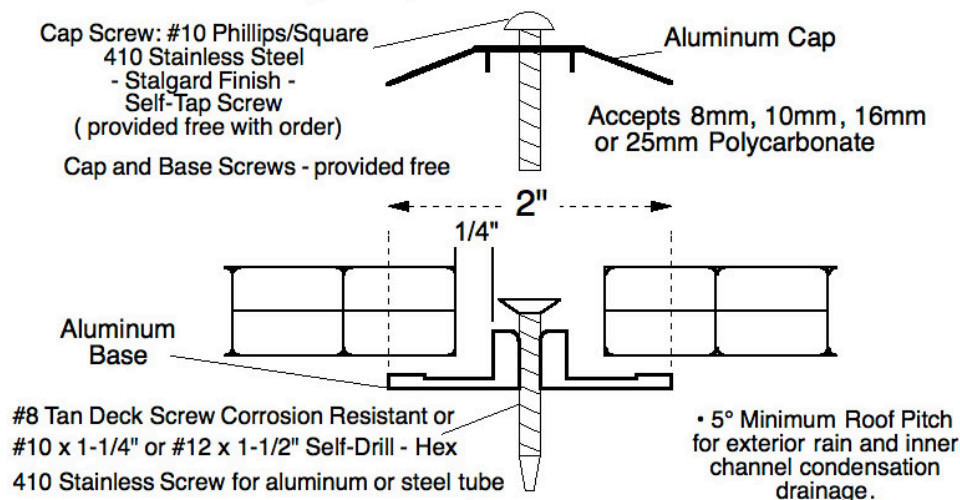

Note: Install base straight or alignment issues may occur when attaching cap. Check with local building codes for recommended purlin/girt spacing to support snow and/or wind structural loads for your area.

Base and Cap Layout - High humidity and cold use for 16mm or 25mm polycarbonate

RIDGE DETAILS

Freestanding Ridge - Gable Style

If the top of the multiwall polycarbonate sheet can not be seen from below, seal the upper edge of the sheet with aluminum tape. If the top of the sheet is visible from below, cover edge of sheet with an aluminum U-profile. (Metal flashing is not included with aluminum base and cap system.)

Ridge Option: Requires Notching in Flashing for Cap

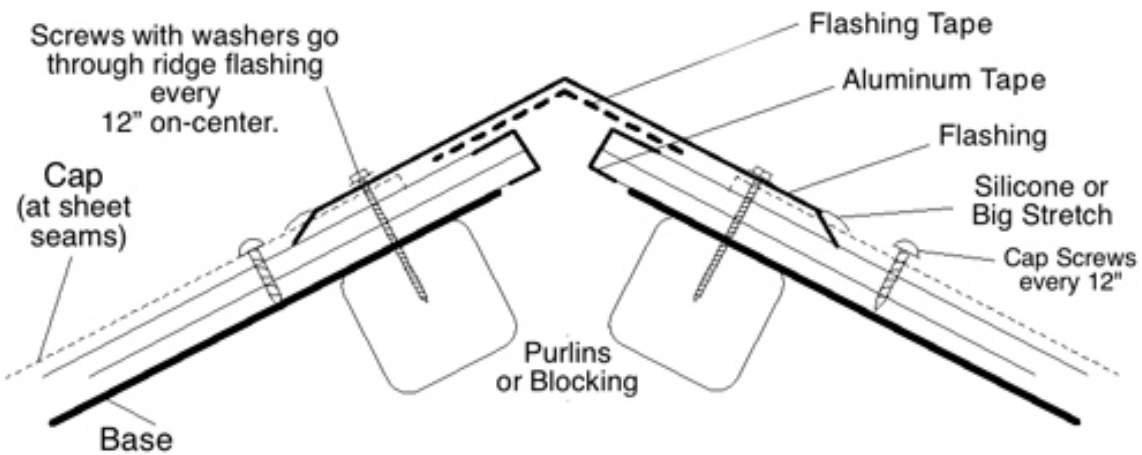

Ridge Option: Hem Bend at 45° (Creates a Sealant Flange)

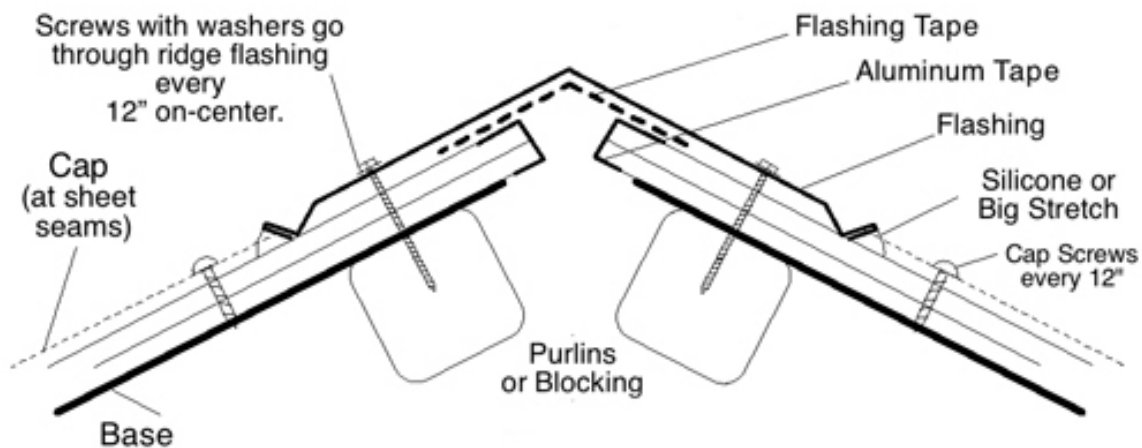

Note: Butt cap to flashing and seal. If using rafters, drawing shows blocking. For applications in high wind areas or expansion and contraction is a concern, use Big Stretch caulk.

We do not provide metal flashing. Please visit your local metal sheet shop for assistance.

RIDGE DETAILS

Hip Flashing - Multiwall Polycarbonate Sheet

If the top of the multiwall polycarbonate sheet can not be seen from below, seal the upper edge of the sheet with aluminum tape. If the top of the sheet is visible from below, cover edge of sheet with an aluminum U-profile. (Metal flashing is not included with aluminum base and cap system.)

Roof Hip: Sheet Joining

- Seal joint with a double layer of adhesive roll flashing.
- Cover with flashing. (Reference illustration to the right.)
- Seal with silicone for weather protection from harsh wind or driving rain.

Note: We recommend working with a local metal sheet shop for custom flashing fabrication.

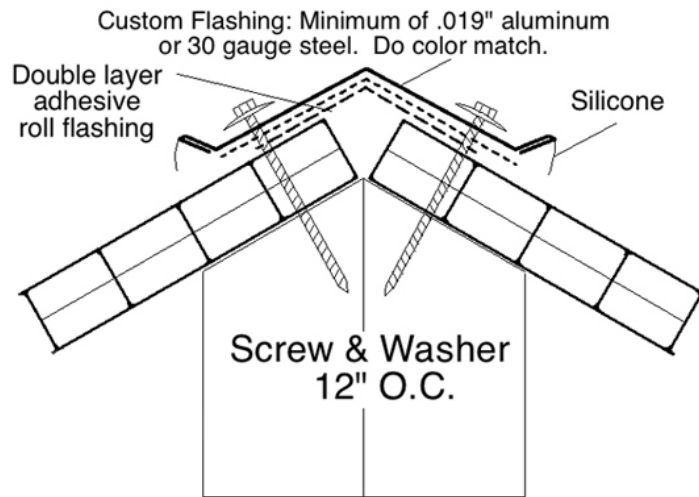

Arch or Quonset Ridge:

- A way to cover arch or quonset using two short sheets that meet at a ridge.
- Screw through multiwall polycarbonate and into purlin every 12" on-center.
- Do not place silicone under or over the cap screws.

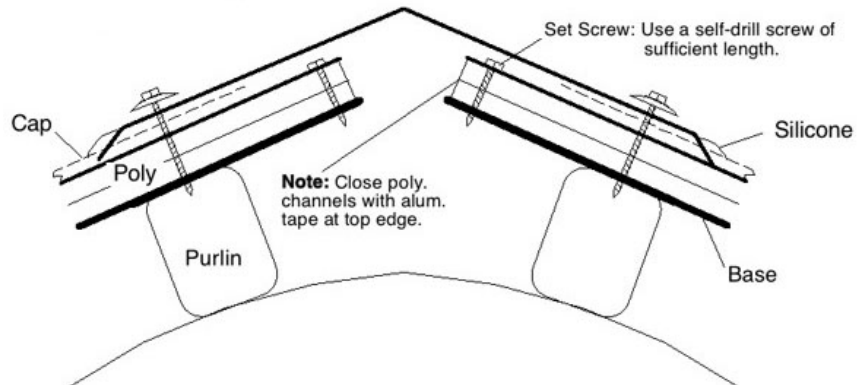

Slight Arch Ridge:

- A way to cover arch using two sheets meeting at ridge.
- Screw through multiwall polycarbonate and into purlin every 12" on-center.
- Do not place silicone under or over the cap screws.

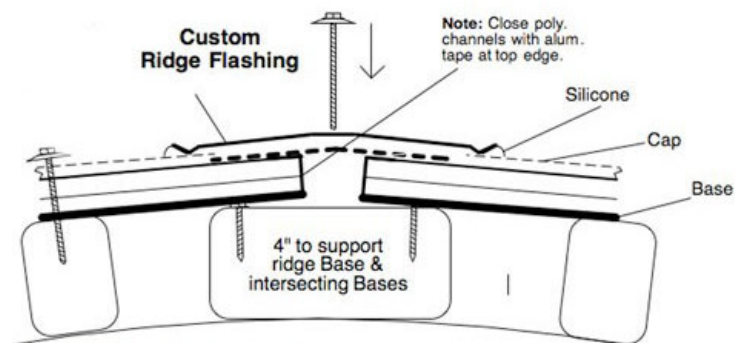

Please contact your local building code office to determine distance between purlins.

RIDGE DETAILS

Freestanding Ridge - Shed Style

If you are slipping the multiwall polycarbonate under an eave or if the top of the sheet can not be seen from below, seal the upper edge of the sheet with aluminum tape. If the top of the sheet is visible from below, cover edge of sheet with an aluminum U-profile. (Metal flashing is not included with aluminum base and cap system.)

Ridge Option: Single Slope

- Dashed line indicates a 3" or 6" wide flashing tape. (Available for purchase.)
- Flashing tape provides an excellent double seal.
- Detail similar for purlin or rafter style framing.

Note: We recommend working with a local metal sheet shop for custom flashing fabrication.

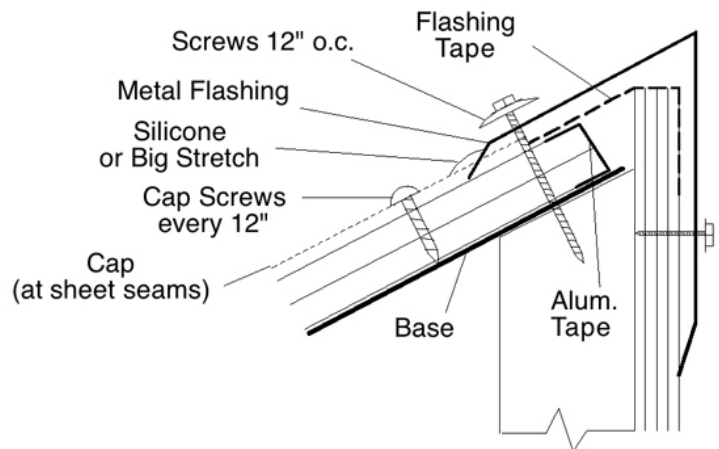

Ridge Option: Attached Lean-To

- This generic illustration covers all options except tucking under existing flashing or new flashing, then adding siding.
- Screw with washers go through ridge flashing every 12" on-center.
- Dashed line indicates a 6" wide flashing tape. (Available for purchase.)
- Flashing tape provides an excellent double seal.
- Use Big Stretch caulk if:
 - Polycarbonate to wood
 - Situations where intense expansion can occur.
- Drawing shows install on roof purlin.
- If using rafters, a beveled ledger board is required.

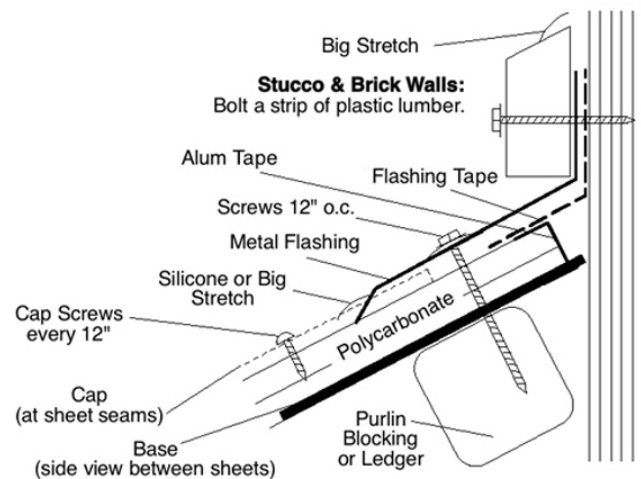

Top Freestanding Patio Cover or Pergola Roof

- Detail of top of pergola, awning, or skylight.
- Screw 12" on-center between caps and through multiwall polycarbonate sheet.
- Do not place silicone under or over the cap screws.

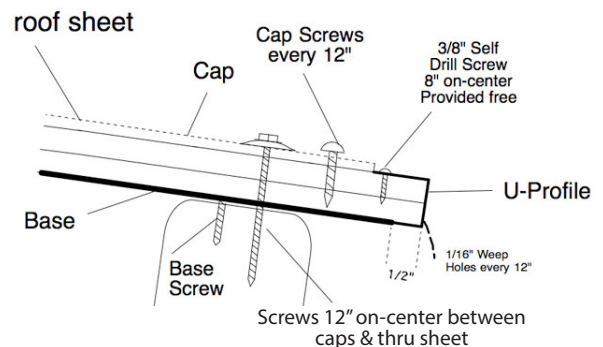

We do not provide metal flashing. Please visit your local metal sheet shop for assistance.

EAVE DETAILS

Rafters and Studs - Multiwall Polycarbonate Sheet

Proper positioning and attachment of your multiwall polycarbonate sheets is important. Sheets should be installed with the flutes running vertically on walls and with the slope of a roof. Make sure to use the correct number of screws along the perimeter and body of the sheet. Screws for the base and cap and U-profile are included. (Metal flashing is not included with aluminum base and cap system.)

Eave Option: Roof to Wall Glazing

- Hold back base as shown in the illustration to the right so the leg of the U-profile will slip onto the multiwall polycarbonate sheet.
- Screw through multiwall polycarbonate 1-1/2" from sheet ends and every 12" on-center.
- Do not place silicone under or over the cap screws.
- Detail similar for purlin and girt or rafter and stud style framing.

Note: Screws for attaching the perimeter and body of sheet are extra. Type and quantity may be job specific. Please reference page 17.

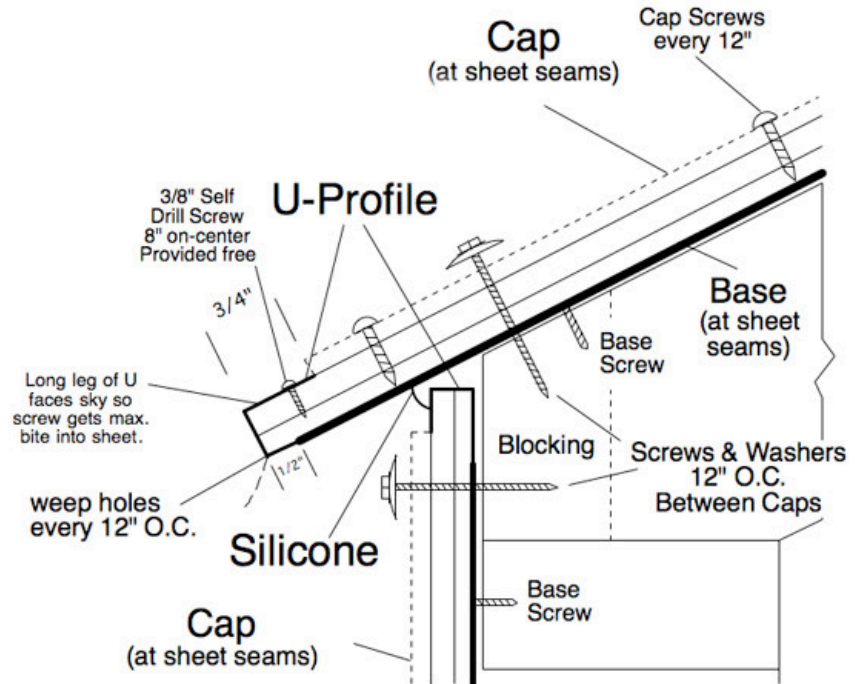

Eave Option: Awning, Pergola, or Skylight

- Detail of top of a pergola, awning, gable (double slope), or arched skylight.
- Screw 12" on-center between caps and through multiwall polycarbonate sheet.
- Do not place silicone under or over the cap screws.

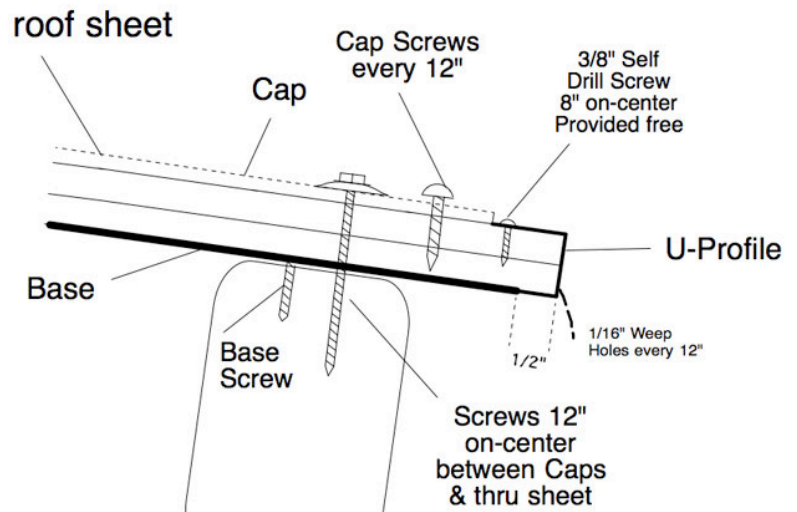

Screws for attaching base to frame and cap to base are included with purchase.

Double Slope Rafters

Gambrel Style Roof

Double slope rafter, also known as gambrel roof, is typically a symmetrical two-sided roof with two slopes on each side. See detail below for simple, effective, way to install multiwall polycarbonate sheet on these types of roofs.

Double Slope: Purlin Detail

- Detail for 'gambrel style' roof.
- Screw 12" on-center between caps and through multiwall polycarbonate sheet.
- Do not place silicone under or over the cap screws.
- Drill weep holes along bottom edge of U-profile to allow for condensation drainage.

U-Profile Install Tip: Position the short leg of the 'U' at a slight angle to the end of the sheet. Begin to wrap, or roll, the 'U' onto the edge of sheet. This creates a tight fitting profile.

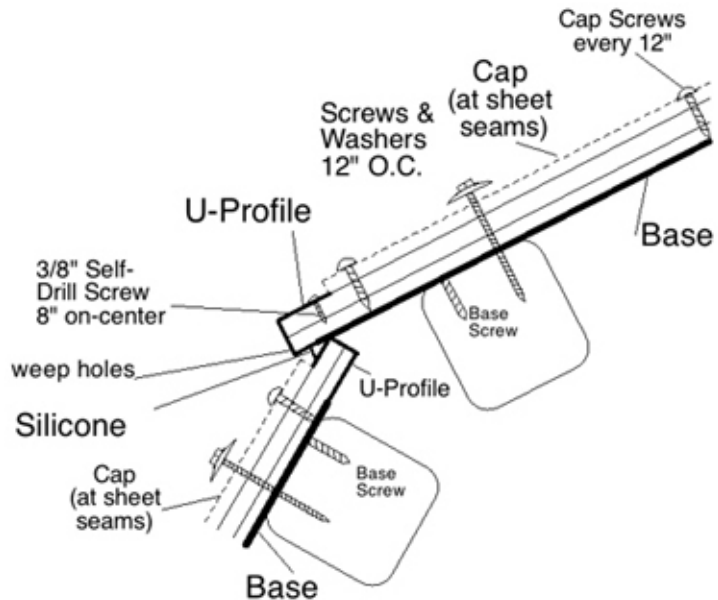

Double Slope: Rafter Detail

- Detail for 'gambrel style' roof.
- Screw 12" on-center between caps and through multiwall polycarbonate sheet.
- Do not place silicone under or over the cap screws.
- Drill weep holes along bottom edge of U-profile to allow for condensation drainage.

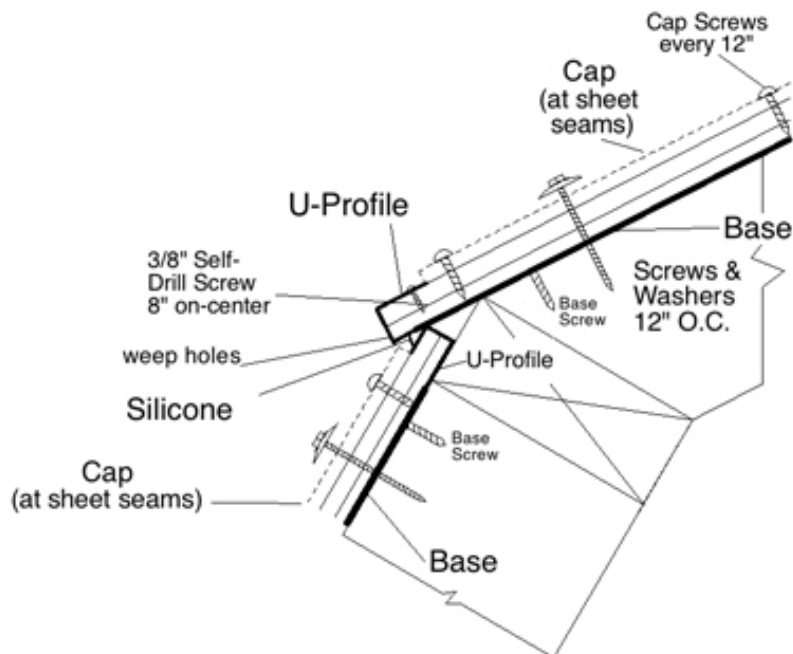

Screws for attaching base to frame and cap to base are included with purchase.

Roof Corners

Polycarbonate Roof Corner Detail

Illustrations below depict common roof corner solutions. It is important for the first and last Base and Cap placement to be 48.5° from the outside edge of first and last rafter or purlin edge. This is so the polycarbonate sheet edge will line up with the outside edge of the framing. Use care when laying out framing.

Roof Corner: Purlin Framing

- Blocking between purlins or tube along rake of roof.
- Screw 12" on-center between caps and through multiwall polycarbonate sheet.
- Do not place silicone under or over the cap screws.

Note: Illustration to right shows polycarbonate sheet on gable end wall. Purlin frame shown. Rafter frame is similar.

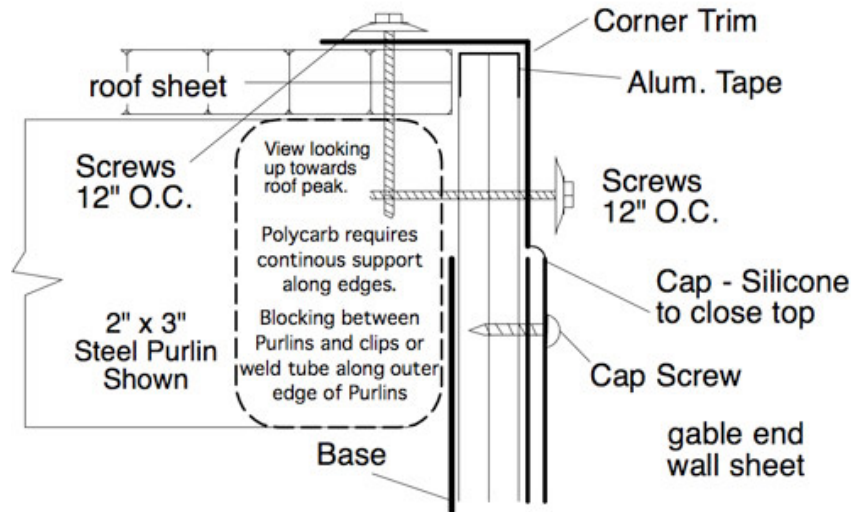

Roof Corner: Rafter and Stud Framing

- Screw 12" on-center between caps and through multiwall polycarbonate sheet.
- Do not place silicone under or over the cap screws.

Note: Illustration to right depicts a typical application with no vertical polycarbonate sheet.

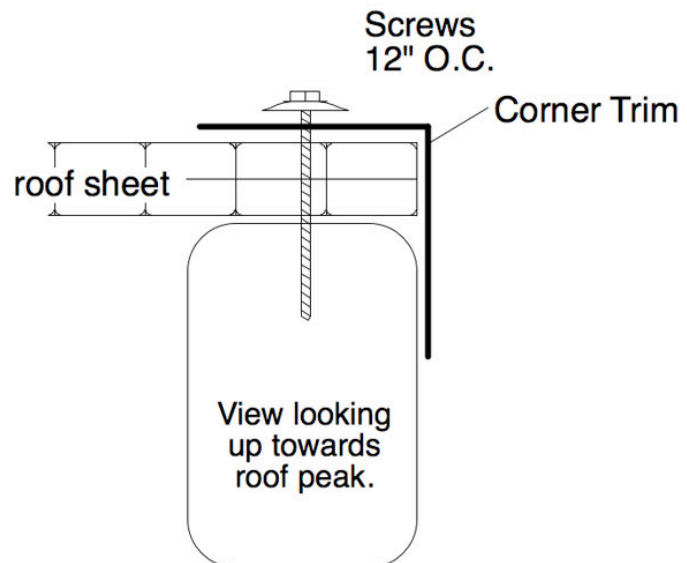

Always pre-drill holes in Base, Cap, and Corner for screw placement.

Roof Corners

Polycarbonate Roof Corner w/Overhang Detail

Illustrations below depict common roof corner solutions. It is important that the first and last rafter placement be less than the standard 24.5" or 49" spacing to achieve the desired 2"-3" overhang. Use care when laying out and placing framing members.

Roof Corner w/Overhang: Poly Gable End

- Illustration to right is generic. Dashed line could be a rafter or blocking between purlins. Use the same basic layout for both framing styles.
- Screw 12" on-center between caps and through multiwall polycarbonate sheet.
- Do not place silicone under or over the cap screws.
- If polycarbonate sheet edge is 'closed' at overhang, a U-profile is not needed.
- If polycarbonate sheet is 'open' at overhang, cover edge with a U-profile.

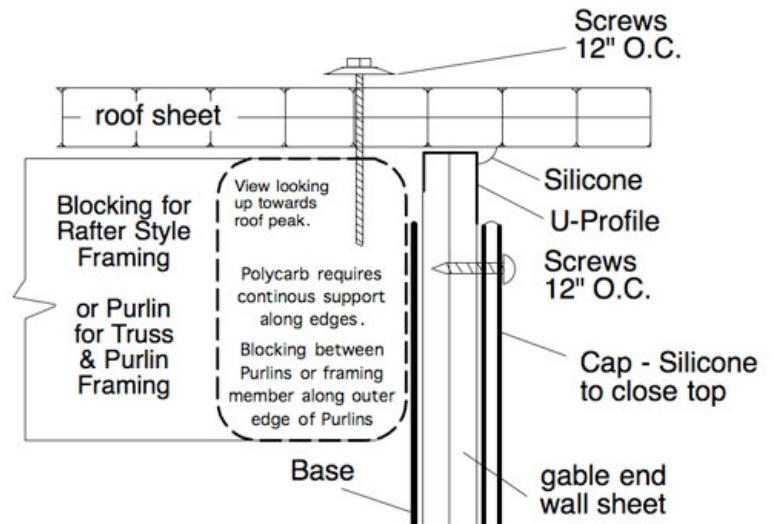

Note: Adjust position of last rafter (or vertical blocking between purlins and framing member) to accommodate overhang and to provide a continuous member to attach polycarbonate sheet to.

Roof Corner w/Overhang: Rafters

- Screw 12" on-center between caps and through sheet.
- Increase quantity of screws as required for load.
- Adjust framing as needed for sheet overhang.
- Do not place silicone under or over the cap screws.

Note: Illustration to right shows typical rafter detail for an awning, pergola, or similar application.

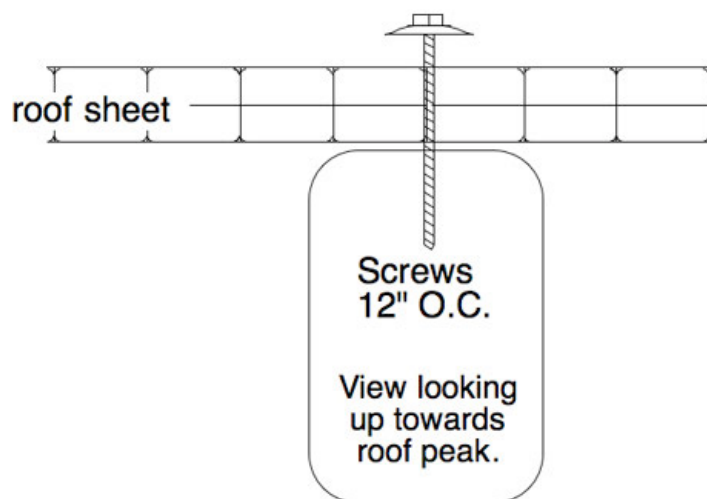

Maximum overhang of 2" or 3" is recommended. Less for thinner gauge poly sheets.

Wall Corners

Polycarbonate Wall Corner Detail

Illustrations below depict common roof corner solutions. Wall corner detail is similar for purlin and girt or rafter and stud style framing. Wall girt framing detail shows blocking laid between wall girts. On rafter and stud framing, the member is simply the vertical stud.

Wall Corner:

- Screw 12" on-center between caps and through multiwall polycarbonate sheet.
- Do not place silicone under or over the cap screws.

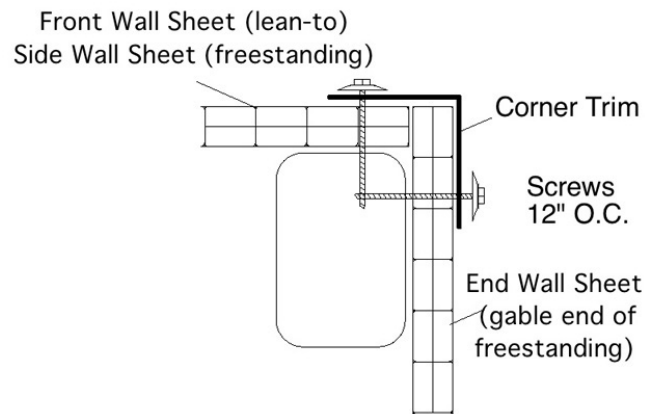

Butt to Siding

Multiwall Polycarbonate Sheet

For those situations where a multiwall polycarbonate sheet butts up to the siding, do not use screws in the U-profile. This will make it easier for the sheet to properly expand and contract in the U-profile.

Polycarbonate: Butt to Siding

- Screw 12" on-center between caps and through multiwall polycarbonate sheet.
- Do not place silicone under or over the cap screws.
- Use Big Stretch caulk to seal gap between siding and polycarbonate sheet.

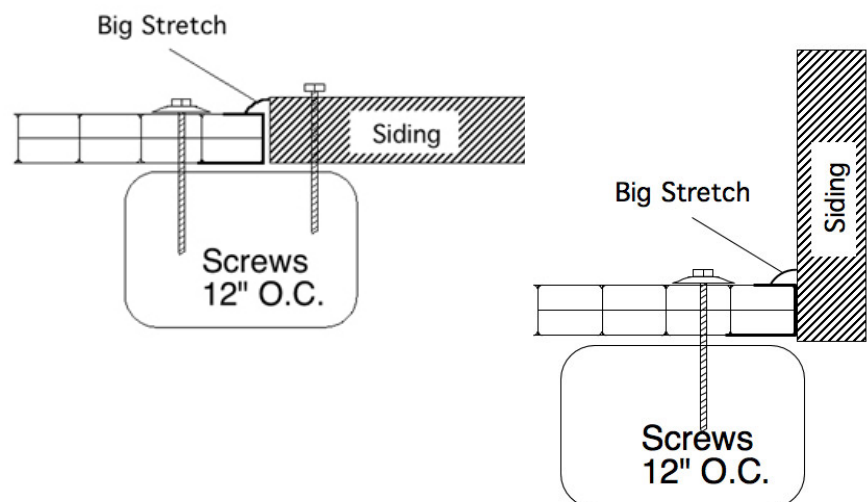

Always pre-drill holes in Base, Cap, and Corner for screw placement.

Clerestory Wall Details

Clerestory Window System for Commercial Applications

When using relatively short sheets of multiwall polycarbonate, builders can simply attach to the horizontal girts at the top and bottom of the sheet. The Base and Cap system is used where the sheet joins and acts as a stiffener, eliminating any bowing of the sheet.

Clerestory:

Ribbon Window Under Eave

- If the multiwall polycarbonate sheet is being tucked under flashing, the sheet's top edge may be sealed with aluminum tape instead of a U-profile.
- A U-profile is needed to seal the bottom edge of the polycarbonate sheet. Don't forget to drill weep holes to allow for proper condensation drainage.
- Screw 12" on-center between caps and through multiwall polycarbonate sheet.
- Do not place silicone under or over the cap screws.
- If framed opening, place Z flashing at base for water drainage.

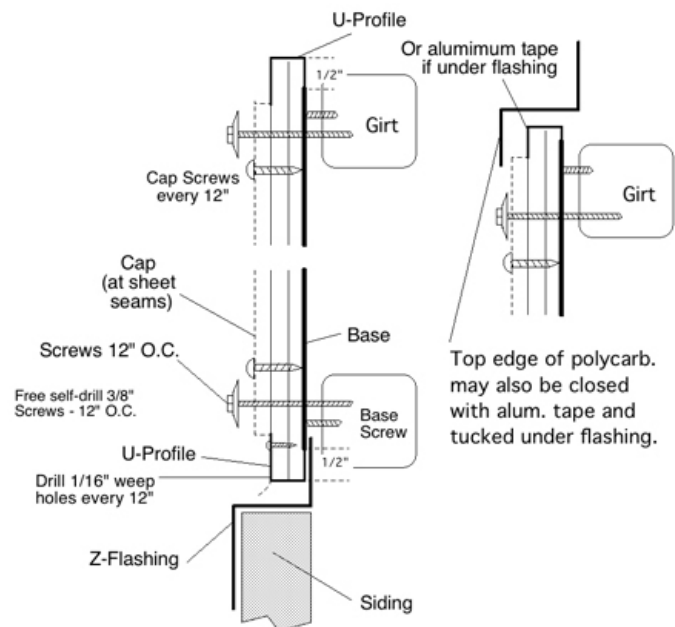

Lower Edge Wall Glazing Details:

- Screw 12" on-center between caps and through multiwall polycarbonate sheet.
- Do not place silicone under or over the cap screws.
- An aluminum U-profile may be used to seal sheet edges at top and end of walls.

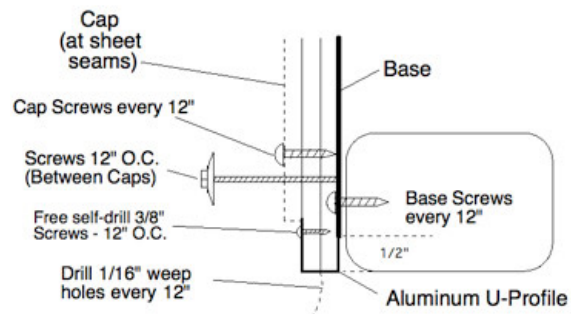

Lower Edge Wall Glazing:

Polycarbonate Overlaps Foundation

- Base screws every 12" or at purlins/girts.
- Screw 12" on-center between caps and through multiwall polycarbonate sheet.
- Do not place silicone under or over the cap screws.
- An aluminum U-profile may be used to seal sheet edges at top and end of walls.

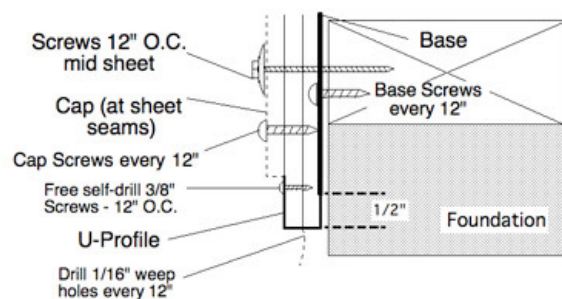

We do not provide metal flashing. Please visit your local metal sheet shop for assistance.

Overlap Details

Overlap - Runs Over 24 Feet

Overlap may be necessary when the roof runs multiwall polycarbonate sheet over 24 feet. Make sure to use a high quality polyethylene backer rod and a 100% silicone that is compatible with polycarbonate. Always lay an initial bead of sealant and cap. Then cap with same sealant after 72 hours.

Base and cap Overlap:

Purlin Frame*

- For 16mm polycarbonate sheet, place continuous 2" wide x 1" high piece of wood, steel, or aluminum tube (shim stock) on existing purlin to bump up top sheet of polycarbonate. Or, simply use a 1" taller purlin. Both are effective solutions for installing a series of very long sheets of polycarbonate.
- For 8mm or 10mm polycarbonate sheets, use 3/4" shim stock.
- For 25mm polycarbonate sheets, use 1-1/2" shim stock (or taller purlins).
- Expansion space is determined by sheet length and temperature swing.
- *Same on continuous rafter.

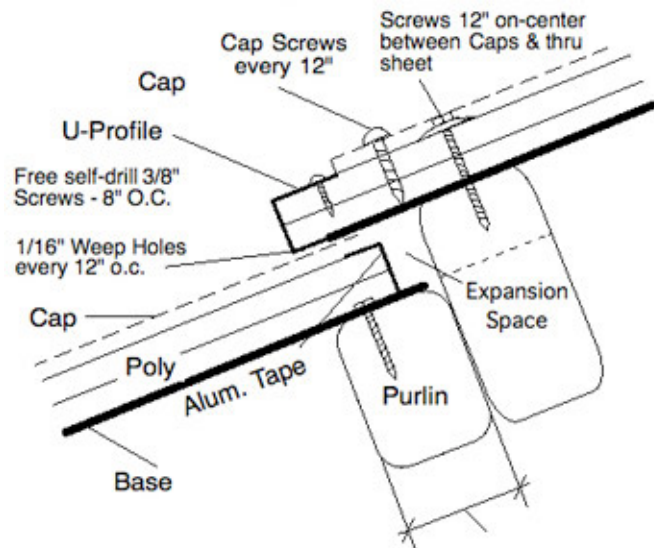

Lower Edge Detail of Overlap

- U-profile covers channels (flutes) of polycarbonate sheet and continues to cover screw receive in Base.
- Fill void at lower end of caps with 100% silicone. (Confirm w/manufacturer silicone is polycarbonate compatible.)
- The upper polycarbonate sheet overlaps the lower sheet by 2" to 6".

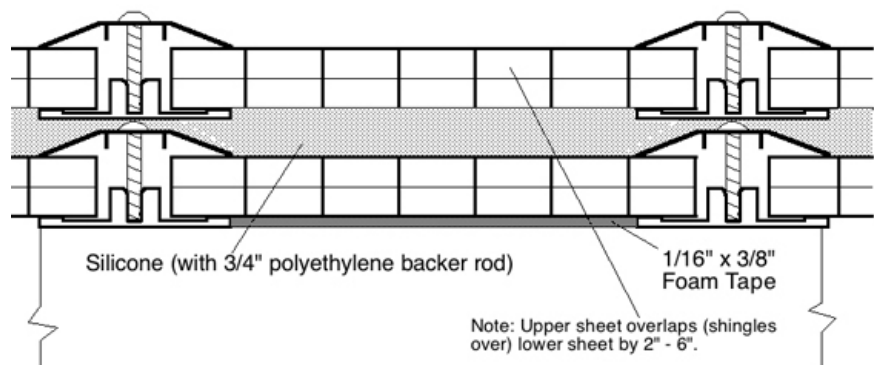

Screws for attaching base to frame and cap to base are included with purchase.

Splice Details

Splice - Runs Over 24 Feet

Splicing may be necessary when the roof runs multiwall polycarbonate sheet over 24 feet. For rafter style framing, simply butt the base extrusions on a common continuous roof rafter. Purlin style framing requires a splice location to be of sufficient width to support the base extrusion.

Base and Cap Splice:

Purlin Frame*

- Butt cap lengths at another location so joints do not line up. This will create a stronger splice.
- Put a bead of 100% silicone along the exterior of cap splice.
- If fastening to an arch, attach each Base with two screws.
- *Same if joint is on a continuous rafter.

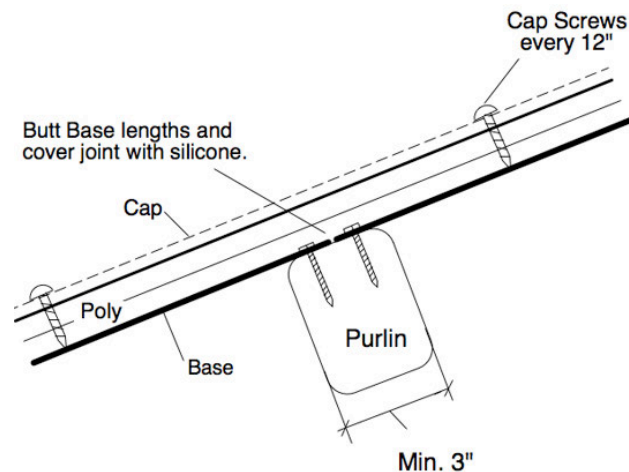

Roof Transition Details

Roof Valley - Multiwall Polycarbonate

AmeriLux does not provide metal flashing. We recommend working with a local metal sheet shop for custom flashing fabrication. We do offer adhesive roll flashing (3" flashing tape) that has butyl adhesive on one side and aluminium foil on the opposite surface.

Roof Valley: Sheet Joining

- Joint is sealed with a double layer of adhesive roll roof flashing.
- Per illustration to right, cover with metal flashing.
- Sikaflex 295UV is required as in initial defense against water seepage.
- Sikaflex is a high performance polyurethane-based adhesive.
- Place sealant over screws, allowing leaves and debris to move past.

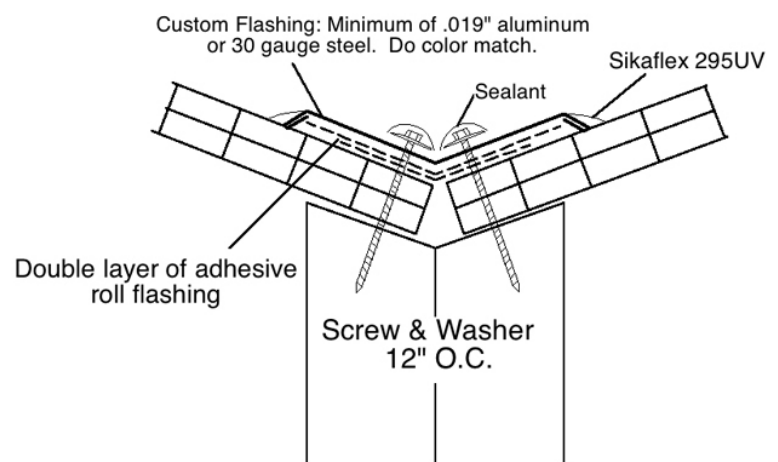

We do not provide metal flashing. Please visit your local metal sheet shop for assistance.

Roof Transition Details

Multiwall Polycarbonate to Existing Roofing

Illustrations below depict common solutions for transitioning from multiwall polycarbonate sheets to your structures roof. These illustrations are generic in nature. They show a typical installation of polycarbonate interfacing with the roofing. Your application may be different, but the basic principles will apply.

Top Detail: Polycarbonate to Standing Seam Metal Roofing

- Illustration to right shows top detail of poly sheet transition to metal roofing.
- Between caps, screw 12" on-center through the multiwall polycarbonate sheet into the purlins.
- Do not place silicone under or over the cap screws.
- Seal sheet's top edge w/aluminum tape.

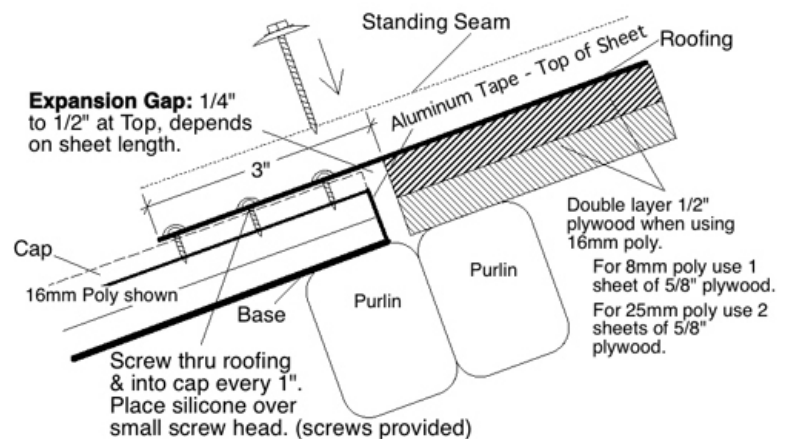

Top Detail: Between Base and Cap

- Illustration to right shows top detail between Base and Cap.
- Between caps, screw 12" on-center through the multiwall polycarbonate sheet into the purlins.
- Do not place silicone under or over the cap screws.

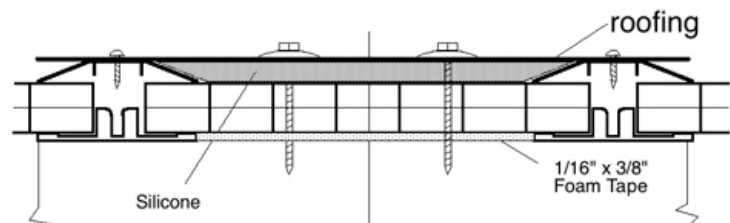

Side Detail: Polycarbonate to Standing Seam Metal Roofing

- Illustration to right shows side detail of poly sheet transition to metal roofing.
- This detail is a typical installation of polycarbonate interfacing with metal roofing while maintaining watertight integrity.
- Make sure to use a 100% silicone that is compatible with polycarbonate.

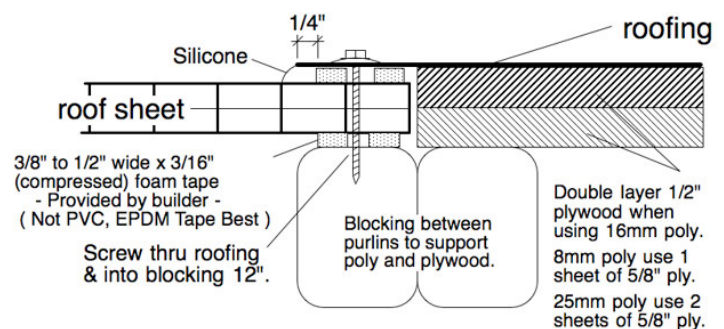

Screws for attaching base to frame and cap to base are included with purchase.

Blocking Spacer w/No Drip Coatings

Rafter Layout - Base and Cap for Polycarbonate

Illustration below depicts common solution for multiwall polycarbonate sheets on vertical rafters. It is recommended to use spacers for high humidity applications such as greenhouse. Spacers allow condensation to move past the blocking and rafter frame.

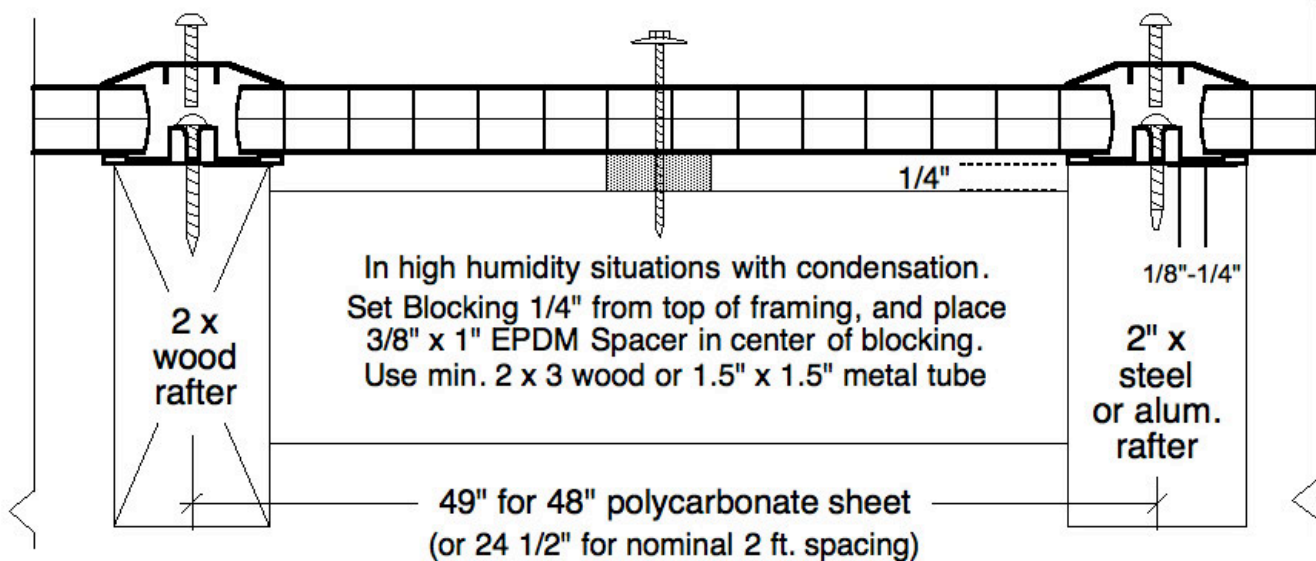

When Using Nominal 2 Foot On-Center Spacing:

- If using corner trim, outside of structure to center of first or last framing member and base is 48-1/2".
- Dimension between intermediate framing members and base is 24-1/2" on-center.
- No spacers needed on blocking, but hold back on 1/4" as shown in illustration.

Note: If sheet to overhang rafter (as it comes down the slope) and 1st and last rafter spacing is less, plan for overhang 2" - 3".

When Using Nominal 4 Foot On-Center Spacing:

- If using corner trim, outside of structure to center of first or last framing member and base is 48-1/2".
- Dimension between intermediate framing members and base is 49" on-center.

Note: Spacer shown in illustration above is 3/8" x 1" x 1". One spacer in the middle of 4 foot sheet; two spaced on a 6 foot sheet.

Screws for attaching base to frame and cap to base are included with purchase.

APPENDIX

Multiwall Polycarbonate Specifications and Notes

Brand Supplied:

- LEXAN™ THERMOCLEAR, LEXAN™ VEROLITE™, LEXAN™ THERMOCLEAR™ Plus, LEXAN™ THERMOCLEAR™ 15, or CoverLite®.
- Other internationally recognized brands may be supplied but only if that brand offers an equal or better warranty, UV-protection, drip guard properties, and light transmission characteristics.
- Install 8mm, 10mm, 16mm, or 25mm polycarbonate on structures with vertical rafters and posts or horizontal purlins set above trusses. (Base attaches to roof purlins and wall girts.)
- **Note:** It is important to store multiwall polycarbonate sheets out of direct sun or the protective masking film may stick to the sheet. Always avoid direct contact with PVC plastic, films, or tapes.

Sheet Thickness:

- +/- .5 mm •• Width +/- 1/8" •• Length +/- 1/4"

Visual Defects:

- Visual defects are defined as bubbles, black specs, gel, etc.
- No visual defects are allowed by inspection from a distance of 1 meter.
- If not visible by using this method, the multiwall polycarbonate sheet will be considered an acceptable product.
- **Note:** Only defects for every 3 linear meters of material with defect size not exceeding 1 mm in diameter, or if not visible from inspection from 1 mm distance will be acceptable.

Condensation:

- Multiwall polycarbonate is not a sealed unit. Condensation will occur between the layers.
- Condensation in the channels (flutes) is normal and is hard to avoid.
- Moisture build up occurs when the temperature and/or humidity is different between the interior and exterior of a structure.
- To ensure proper condensation drainage, install sheets with the channels (flutes) running vertically.

Expansion and Contraction:

- Multiwall polycarbonate expands in hot weather and contracts in cold. (Approx. 1/32" per foot for 100° of temperature change.) For best results, sheets should be installed between 55°F and 70°F.
- Cold nights/warm sunny days can result in dramatic temperature swings. This may cause the sheet to make a creaking noise. This is a normal as the sheet expands/contracts along the framing members.
- **Note:** Bronze sheets get warmer in the sun and it will be hotter under the panel, even though the light and solar transmission is less. Bronze expands and contracts 30% more than clear or opal.

Roof Slope:

- A minimum 2/12 roof pitch is required in areas with there is substantial rain, trees overhead drop pollen (or other tiny particles), or extremely damp areas.
- These conditions will cause mold and mildew to breed. It is crucial in these types of situations that the water cascades off the roof, keeping the multiwall polycarbonate clean.

APPENDIX

Polycarbonate Install System - Aluminum Base and Cap

Vent Tape Not Required:

- Vent tape is not needed when an aluminum U-profile is used. The base and cap aluminum U-profile fits snugly and does not require vent tape to keep bugs and dust out of the polycarbonate flutes.
- Weep holes are required in the low side U-profile (approximately 12" on-center).
- Long edge of U-profile goes up. The leading high edge and the beveled leading edge on the long leg of the U-Profile help to eliminate entry of water (often laden with clogging dust and pollen).
- The 3/8" screws (8-12" on-center on long leg of U-profile) may cause the sheet to dimple slightly.

Polycarbonate Sealant Usage:

- Dow 999-A: This sealant is specially formulated to be plastics compatible, adhering well to polycarbonate and metals – not wood. Clean areas to be sealed with a soft cloth slightly saturated with rubbing alcohol. Let dry and apply a thin bead of silicone (1/4" x 1/4").
- Big Stretch: This sealant works well for polycarbonate to wood applications. (Often used at ridge flashing to polycarbonate, where higher winds may be present.) Clean areas to be sealed with a soft cloth slightly saturated with rubbing alcohol. Let dry and apply a thin bead of silicone (3/16" x 3/16").
- Sikaflex 295-UV: This super strong sealant works well in polycarbonate to wood applications. (Often used at ridge flashing to polycarbonate, where higher winds may be present.) Clean areas to be sealed with a soft cloth slightly saturated with rubbing alcohol. Let dry and apply a thin bead of silicone (1/4" x 1/4").
- **Note:** A 100% silicone is recommended if the above products are not available or applicable. Always read and follow sealant instructions.

Screw Information: Cap Screws

- 410 Stainless Steel 10-32 Trilobular Screws with Silver Stalgard® corrosion resistant surface. (Cap seals tight!)
- A minimum roof pitch of 5° or greater is recommended for high humidity applications.
- Screw threads 1/16" beyond tip engagement. (Tip engages swiftly.)

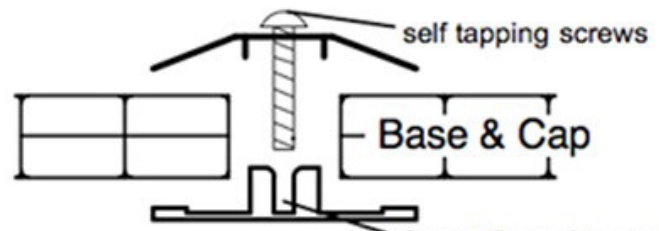

Trilobular Screws: #2 Phillips-Sq. Combo. Round tip for swift threading into screw race. Hurricane Strong!

Screw Information: Base Screws

For Wood:

- #8 x 1-5/8", Tan Deck Type - Corrosion Resistant
- We recommend using this type of screw even with pressure treated lumber.

For Metal:

- #410 Stainless Steel, Type 3 Drill Point
- Maximum .187" Steel or Aluminum

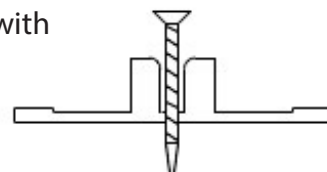

Pre-drill Base for
attaching Base Screws

APPENDIX

Polycarbonate Install System - Aluminum Base and Cap

Base and Cap: Screw Count Procedure

- Screws for attaching Base, Cap, and U-profile are included with the Base and Cap system. Always pre-drill holes in Base, Cap, and Corner for screw placement. Self-drilling screws are 'never' meant to drill through these components. Self-drill screws pass through components, fastening both to the frame.
 - Screws for attaching the perimeter are extra. Type and quantity may be job specific.
 - Screw count for perimeter of roof, walls, in corners, flashing, around doors, windows, and fans, and in the body of the polycarbonate sheet:
 - #10 x 2" wood or #12 x 1-1/2" self-drilling metal screws with 3/4" sealing washers (Used when screwing through 8mm, 10mm and 16mm polycarbonate sheets.)
 - #10 x 2-1/2" wood or #12 x 2" self-drilling metal screws with 3/4" sealing washers (Used when screwing through 25mm polycarbonate sheets.)
 - Roof or High Wind Area:
 - Use 1 screw per foot along the top edge of roof slope. Set screw through ridge flashing - into purlin or blocking below.
 - Use 1 screw per foot along lower edge of sheet, position between Base and Cap.
 - Aluminum Corner Trim (1 screw 2" from ends and every 12" along each leg of corner).
 - Walls or High Wind Area:
 - Aluminum corner trim (1 screw 2" from ends and every 12" along each leg of corner).
 - On side or front walls, 1 screw per foot along top and bottom edge of sheet, position between Base and Cap. Screw goes through the sheet, into the girts or top and bottom plates.
 - On gable ends with corner trim at top of sheet, 1 screw per foot along the bottom edge of sheet and position between Base & Cap. Screw goes through sheet and into girts or bottom plates. (See above for screw placement in corner trim.)
 - Around Doors, Fans, and Shutters:
 - 1 screw every 12" around the perimeter of these areas as needed.
- Note:** Base and Cap screws are provided with order. When placing order, specify wood or metal frame. In addition, screws for aluminum U-profile are also provided with order.

U-Profile: Screw Count Procedure

- Use 3/8" self-drill screws to secure lower roof U-profile supplied free with order of U-profile.
- A sufficient number of self-drill screws are provided should customer choose to use in all locations.
- Screws are color matched. At lower edge of slope (eave), set screws every 8" on-center.
- When using these screws at other locations, set them 12" on-center.
- **Note:** Base Screws are attached to roof purlins and wall girts as laid out in your design. If attaching to rafters position, 1" from ends and about every 12" on-center. Cap screws are positioned 1-1-2" from ends and about every 12" on-center.

Always Pre-Drill Base and Cap!

- Note: Self Tapping screws engage even when the screw is set at a slight angle.
- Tip Design:



APPENDIX

Polycarbonate Install System - Aluminum Base and Cap

Why Choose Base and Cap?

- Easy to Install: Simply attach Base, lay multiwall polycarbonate sheet, and attach Cap.
- Leakproof System: The aluminum Cap creates a tight seal on the polycarbonate sheet.
- Cap Screws Set Quickly: The Cap screws seal tight.
- Versatile: Cap screw length will accommodate many polycarbonate sheet thicknesses.
- Strong: Aluminum Base profile will span over and attach to purlins.

Applications:

- This aluminum Base and Cap system is ideal for a greenhouse, pool enclosure, large skylight, or metal building frame.
- Rafter and post framing allows the multiwall polycarbonate sheet 'condensation' move past the blocking. If condensation is an issue with a purlin and girt structure, 16mm sheet is recommended.
- For high humidity applications such as a pool enclosure, 25mm polycarbonate sheets work well.

General Installation Tips:

- Multiwall polycarbonate sheet must be supported on all 4 edges with a minimum of 1/2" of the sheet bearing on the Base or frame.
- When using polycarbonate sheets that are cut along the width and no longer have a 'rib' at the edge, position the sheet so the first rib is supported by a minimum of 1/2".
- Position sheet so the UV protected side of the sheet faces up or towards the sun.
- Remove the protective film from both sides of the sheet prior to installation.
- When using adhesive roll flashing (aluminum tape), make sure the sheet surface is clean and free of moisture and contamination. Start by peeling off a few inches of the release liner and attaching the tape. Press down firmly on the center of the tape and work towards the edge to remove any air bubbles. Do not 'stretch' the tape during application!
- It is extremely important to use the right screw in the proper location. Do not assume you know where the screws go. Always refer to the install illustration specific to the detail you are addressing.

Install Policy:

- By placing an order, the customer agrees to the installation policy. Per this agreement, the customer agrees to follow the installation guidelines and details or be fully responsible for any adverse consequences due to not following the installation instructions.
- Often installers do not follow installation instructions and problems occur such as leakage, noise, excessive flexing of the multiwall polycarbonate sheets, etc.
- If problems occur with materials during installation, contact AmeriLux International @ 888-602-4441 immediately for assistance. Proceeding with your own solution could easily create more problem and may actually void the multiwall polycarbonate sheet warranty.

